

ITEM NO.	PART NUMBER	DESCRIPTION	QTY.
1	M13592	PADDLE WEAR PAD	1
2	M13606-RH-M	PADDLE FAB RH	1
3	M13609	BEARING BLOCK	2
4	M14124	NUT, HEX, .5" NC	6
5	M14361	BOLT, HHCS, .50" X 3.50" NC GR5	4
6	M14495	BOLT, FHSCS, .50" X 2"	2

ITEM NO.	PART NUMBER	DESCRIPTION	QTY.
7	M14645	SPHERICAL BEARING	2
8	M16086	GREASE ZERK, 1/8 NPT	2
9	M50259	BOLT, HHCS, .75" X 5.50" NC GR8	1
10	M16772	SPLIT COLLAR	2
11	M17649	WASHER, FLAT, .50"	4
12	M16321	NUT, LOCK, .75"	1
13	M17653	WASHER, FLAT, .75"	1

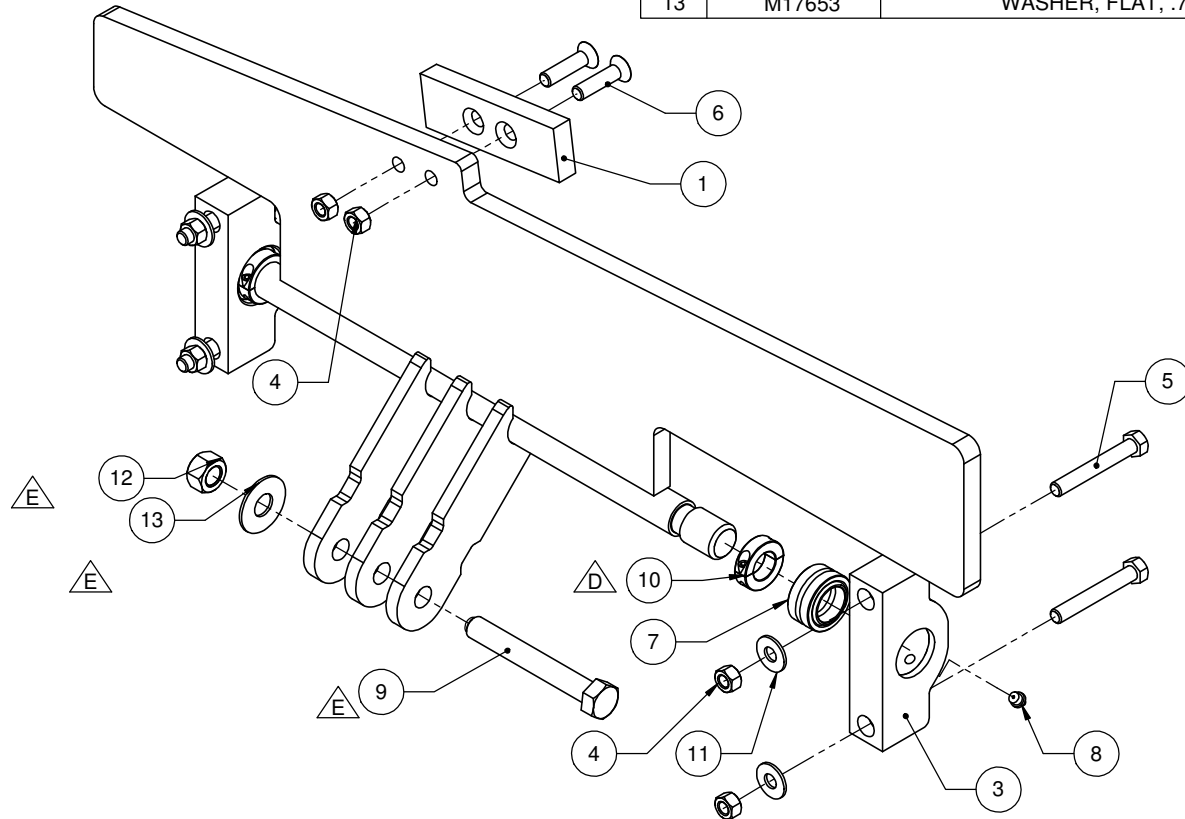

ECN	REV	DESCRIPTION	DRAWN	CHECKED	DATE	UNLESS OTHERWISE STATED - ALL SHARP EDGES TO BE GROUND R0.125" - ALL WELDS IN ACCORDANCE WITH AWS D1.1 and KWS-001 - MARK/STAMP PT. # AND/OR W.O. # ON PARTS - Q ± 0.063	TOLERANCE UNLESS OTHERWISE SPECIFIED X" ± .5" X.X" ± .25" X.XX" ± .125" X.XXX" ± .063" X.XXXX" ± .010" X" ± 1"	MIE SUPPLY		PROPRIETARY AND CONFIDENTIAL THE INFORMATION CONTAINED IN THIS DRAWING IS THE SOLE PROPERTY OF MIE SUPPLY. ANY REPRODUCTION IN PART OR AS A WHOLE WITHOUT THE WRITTEN PERMISSION OF MIE SUPPLY IS PROHIBITED.	
-	A	RELEASED FOR MANUFACTURING									
0825	B	ADD DRAG LINK SPACERS									
1034	C	REMOVE SPACERS 107-300-023-901									
1043	D	CHANGE SNAP RING TO SPLIT COLLAR				MATERIAL N/A					
1126	E	CHANGE SHOULDER BOLT TO GRADE 8 BOLT				COATING N/A					
	F	CHANGED DWG'S TO SAP-M'S				DO NOT SCALE ALL DIMENSION IN INCHES					
	G	CHANGED PADDLE FAB TO -M									
			I	H	G	F	E	D	C	B	A
										DWG. No: _____ SAP. No: N/A    WT: 21.497 LBS    SHEET 1 OF 1	
										REV.: <b>G</b>	