

ITEM NO.	PART NUMBER	DESCRIPTION	QTY.
1	107-700-227-00	SCRAPER HEAD FRAME ASSEMBLY	1
2	107-701-130-00	O.D. SCRAPER (7) CUTTER WHEEL UNIT	1
3	107-701-131-00	O.D. SCRAPER (6) CUTTER WHEEL UNIT	1

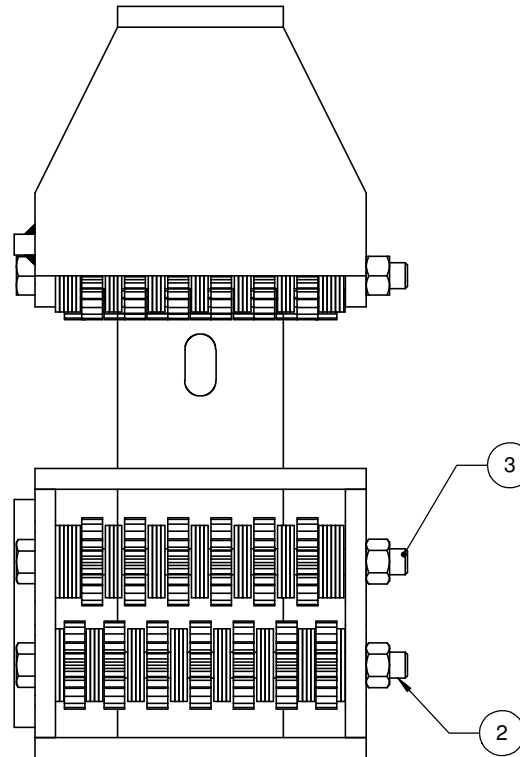

**BOTTOM VIEW**

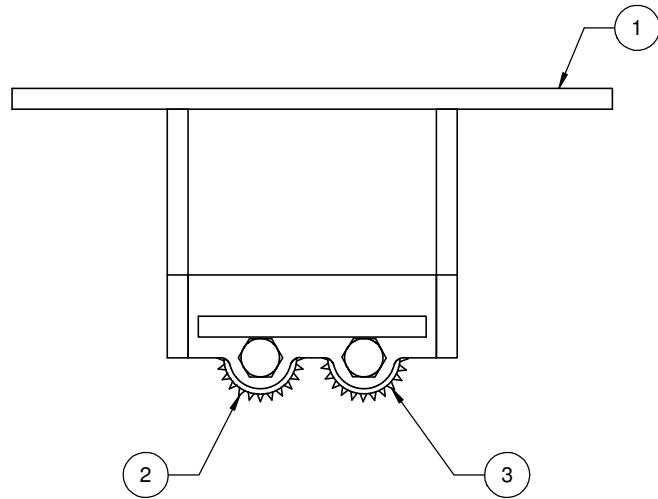
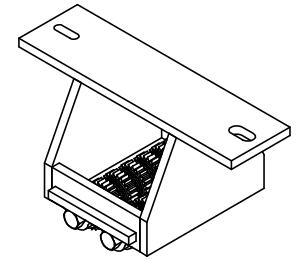

ECN	REV	DESCRIPTION	DRAWN	CHECKED	DATE	UNLESS OTHERWISE STATED	TOLERANCE UNLESS OTHERWISE SPECIFIED	PROPRIETARY AND CONFIDENTIAL	
-	A	RELEASED FOR MANUFACTURING				- ALL SHARP EDGES TO BE GROUNDED TO .125" - ALL WELDS IN ACCORDANCE WITH AWS D1.1 and S-001 - MARK/STAMP PT. # AND/OR W.O. # ON PARTS	X" ± .5" X.X" ± .25" X.XX" ± .125" X.XXX" ± .063" X.XXXX" ± .010" X" ± 1"	TITLE: <b>SCRAPER HEAD ASSEMBLY</b>	
	B					- $\phi \pm 0.063$		DWG. No:	
	C					MATERIAL		REV.: <b>A</b>	
	D					N/A		SAP. No:	
	E					COATING		WT: 24.706 LBS	
						N/A		SHEET 1 OF 1	
						DO NOT SCALE ALL DIMENSION IN INCHES	3rd ANGLE PROJECTION		
I		H	G	F	E	D	C	B	A



DRAWN: \_\_\_\_\_ BY: \_\_\_\_\_ DATE: \_\_\_\_\_  
 CHECKED: \_\_\_\_\_  
 APPROVED: \_\_\_\_\_