

ITEM NO.	PART NUMBER	DESCRIPTION	QTY.
1	M8288	(8288) CYLINDER CUTTER, 1110506	14
2	M14324	HBOLT, 5/8 IN. NC x 9 IN. LG	2
3	M17651	WASHER, FLAT, .625"	56
4	M16532	NUT, LOCK, .625" NC NYLOCK	1

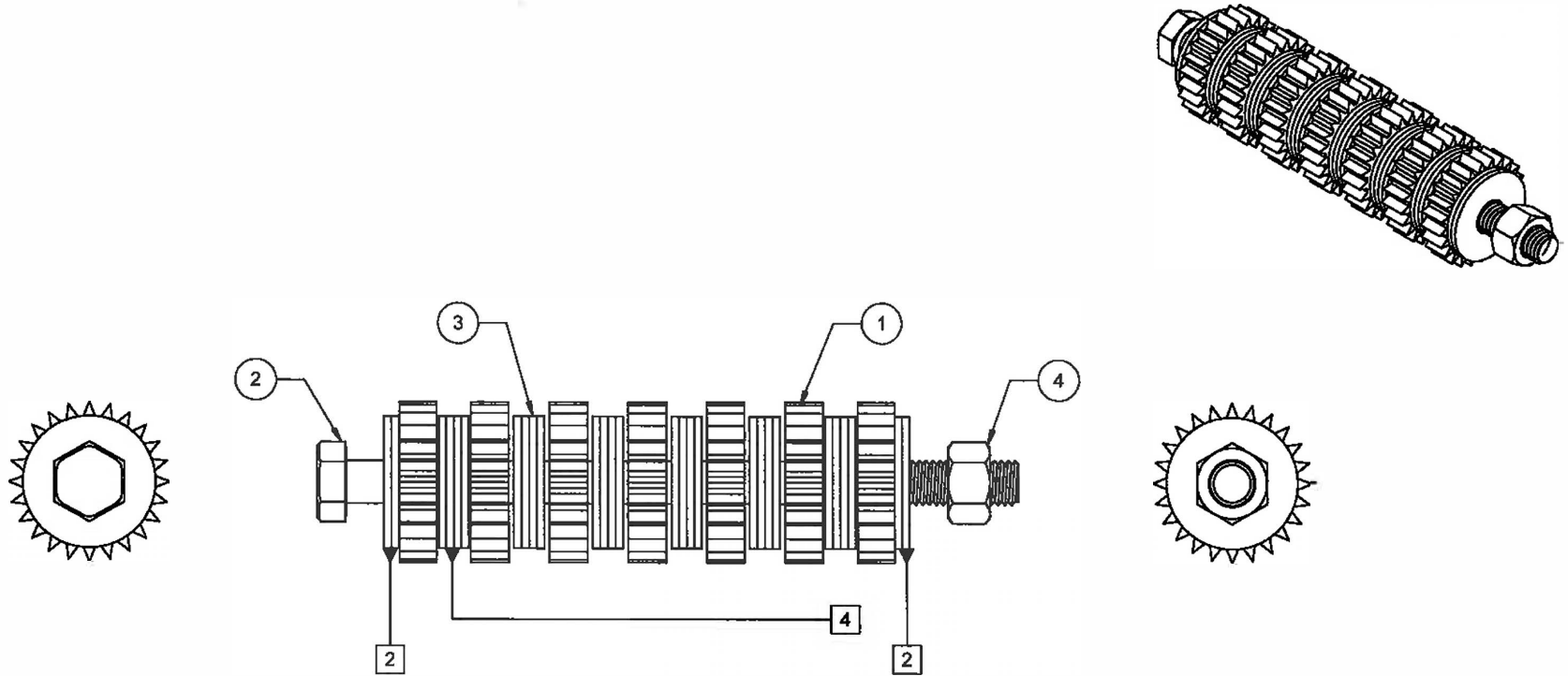

ECN	REV	DESCRIPTION	DRAWN	CHECKED	DATE	UNLESS OTHERWISE STATED - ALL SHARP EDGES TO BE GROUND - 0.125" RADIUS - ALL WELDS IN ACCORDANCE WITH AWS D1.1 - ALL WELD BEVEL ANGLES 30°	TOLERANCE UNLESS OTHERWISE SPECIFIED		PROPRIETARY AND CONFIDENTIAL	
-	A	RELEASED FOR CONSTRUCTION	FLS	JBB	11/09/12	MATERIAL N/A	X" ± .5" X.X" ± .25" X.XX" ± .125" X.XXX" ± .063" X.XXXX" ± .010" X" ± 1"		DATE: 11/09/12	DWG. No:
						COATING N/A	3rd ANGLE PROJECTION	CHECKED: JBB 11/09/12	O.D. SCRAPER (14) CUTTER WHEEL UNIT	
						DO NOT SCALE ALL DIMENSION IN INCHES		APPROVED: JBB 11/09/12	OD SCRAPER ASSY	
									WT: 0.618 LBS	SHEET 1 OF 1



